



MINI MICRO™

Orbital Weldhead Owner's Manual

Product:	Mini Micro
Manual:	091-0510
Serial:	02020001
Voltage Rating:	N/A
Revision:	May 2002 Rev A
Model Number:	4000



SAFETY CONSIDERATIONS

ELECTRIC ARC WELDING EQUIPMENT

CAUTION : READ BEFORE ATTEMPTING INSTALLATION, OPERATION OR MAINTENANCE OF THIS EQUIPMENT

1-1 INTRODUCTION

This equipment is intended for ultimate application by commercial/industrial users and for operation by persons trained and experienced in the use and maintenance of welding equipment. Operation should not be undertaken without adequate training in the use of such equipment. Training is available from many public and private schools or similar facilities.

Safe practices in the installation, operation and maintenance of this equipment requires proper training in the art, a careful study of the information provided with the equipment, and the use of common sense. Rules for safe use are generally provided by suppliers of welding power sources, compressed gas suppliers, and electrode suppliers. Careful compliance with these rules will promote safe use of this equipment.

The following Safety Rules cover some of the more generally found situations. READ THEM CAREFULLY. In case of any doubt, obtain qualified help before proceeding.

1-2 GENERAL PRECAUTIONS

A. Burn Prevention

ELECTRIC ARC WELDING PRODUCES HIGH INTENSITY HEAT AND ULTRAVIOLET RADIANT ENERGY WHICH MAY CAUSE SERIOUS AND PERMANENT EYE DAMAGE AND WHICH MAY DAMAGE ANY EXPOSED SKIN AREAS.

Wear helmet with safety goggles or glasses with side shields underneath, appropriate filter lenses or plates (protected by clear cover glass). This is a must for welding or cutting (and chipping) to protect the eyes from radiant energy and flying metal. Replace cover glass when broken, pitted, or spattered.

Medical first aid and eye treatment. First aid facilities and a qualified first aid person should be available for each shift unless medical facilities are close by for immediate treatment of flash burns of the eyes and skin burns.

Wear protective clothing - leather (or asbestos) gauntlet gloves, hat, and high safety-toe shoes. Button shirt collar and pocket flaps, and wear cuffless trousers to avoid entry of sparks and slag.

Avoid oily or greasy clothing. A spark may ignite them.

Flammable hair preparations should not be used by persons intending to weld or cut.

Hot metal such as electrode stubs and work pieces should never be handled without gloves.

Ear plugs should be worn when working on overhead or in a confined space. A hard hat should be worn when others work overhead.

B. Toxic Fume Prevention

WARNING: The use of this product may result in exposure to chemicals known to the State of California to cause cancer and birth defects or other reproductive harm.

Adequate ventilation. Severe discomfort, illness or death can result from fumes, vapors, heat, or oxygen enrichment or depletion that welding (or cutting) may produce. Prevent them with adequate ventilation. NEVER ventilate with oxygen.

Lead-, cadmium-, zinc-, mercury-, beryllium-bearing and similar materials, when welded or cut, may produce harmful concentrations of toxic fumes. Adequate local exhaust ventilation must be used, or each person in the area, as well as the operator, must wear an air-supplied respirator. For beryllium, both must be used.

Metals coated with or containing materials that emit toxic fumes should not be heated unless coating is removed from the work surface, the area is well ventilated, or the operator wears an air-supplied respirator.

Work in a confined space only while it is being ventilated and, if necessary, while wearing an air-supplied respirator.

Gas leaks in a confined space should be avoided. Leaked gas in large quantities can change oxygen concentration dangerously. Do not bring gas cylinders into a confined space.

Leaving confined space, shut OFF gas supply at source to prevent possible accumulation of gases in the space if downstream valves have been accidentally opened or left open. Check to be sure that the space is safe before reentering it.

Vapors from chlorinated solvents can be decomposed by the heat of the arc (or flame) to form PHOSGENE, a highly toxic gas, and other lung and eye irritating products. The ultraviolet (radiant) energy of the arc can also decompose trichloroethylene and perchloroethylene vapors to form phosgene. DO NOT WELD or cut where solvent vapors can be drawn into the welding or cutting atmosphere or where the radiant energy can penetrate to atmospheres containing even minute amounts of trichloroethylene or perchloroethylene.

C. Fire and Explosion Prevention

Causes of fire and explosion are: combustibles reached by the arc, flame, flying sparks, hot slag, or heated material, misuse of compressed gases and cylinders, and short circuits.

BE AWARE THAT flying sparks or falling slag can pass through cracks, along pipes, through windows or doors, and through wall or floor openings, out of sight of the goggled operator. Sparks can fly many feet.

To prevent fires and explosion:

Keep equipment clean and operable, free of oil, grease, and (in electrical parts) of metallic particles that can cause short circuits.

If combustibles are in area, do NOT weld or cut. Move the work if practicable, to an area free of combustibles. Avoid paint spray rooms, dip tanks, storage areas, ventilators. If the work cannot be moved, move combustibles at least 35 feet away, out of reach of sparks and heat; or protect against ignition with suitable and snug-fitting, fire-resistant covers or shields.

Walls touching combustibles on opposite sides should not be welded on (or cut). Walls, ceilings, and floor near work should be protected by heat-resistant covers or shields.

Fire watcher must be standing by with suitable fire extinguishing equipment during and for some time after welding or cutting if:

1. Appreciable combustibles (including building construction) are within 35 feet.
2. Appreciable combustibles are further than 35 feet, but can be ignited by sparks.
3. Openings (concealed or visible) in floors or walls within 35 feet may expose combustibles to sparks.
4. Combustibles adjacent to walls, ceilings, roofs, or metal partitions can be ignited by radiant or conducted heat.

Hot work permit should be obtained before operation to ensure supervisor's approval that adequate precautions have been taken.

After work is done, check that area is free of sparks, glowing embers, and flames.

An empty container that held combustibles, or that can produce flammable or toxic vapors when heated, must never be welded on or cut, unless container has first been cleaned in accordance

with industry standards.

This includes: a thorough steam or caustic cleaning (or a solvent of water washing, depending on the combustible's solubility), followed by purging and inerting with nitrogen or carbon dioxide, and using protective equipment.

Water-filling just below working level may substitute for inerting.

A container with unknown contents should be cleaned (see paragraph above). Do NOT depend on sense of smell or sight to determine if it is safe to weld or cut.

Hollow castings or containers must be vented before welding or cutting. They can explode.

Explosive atmospheres. NEVER weld or cut where the air may contain flammable dust, gas, or liquid vapors (such as gasoline).

D. Compressed Gas Equipment

The safe handling of compressed gas equipment is detailed in numerous industry publications. The following general rules cover many of the most common situations.

1. Pressure Regulators

Regulator relief valve is designed to protect only the regulator from over-pressure; it is not intended to protect any downstream equipment. Provide such protection with one or more relief devices.

Never connect a regulator to a cylinder containing gas other than that for which the regulator was designed.

Remove faulty regulator from service immediately for repair (first close cylinder valve). The following symptoms indicate a faulty regulator:

Leaks - if gas leaks externally.

Excessive Creep - if delivery pressure continues to rise with downstream valve closed.

Faulty Gauge - if gauge pointer does not move off stop pin when pressurized, nor returns to stop pin after pressure release.

Repair. Do NOT attempt repair. Send faulty regulators for repair to manufacturer's designated repair center, where special techniques and tools are used by trained personnel.

2. Cylinders

Cylinders must be handled carefully to prevent leaks and damage to their walls, valves, or safety devices:

Avoid electrical circuit contact with cylinders including third rails, electrical wires, or welding circuits. They can produce short circuit arcs that may lead to a serious accident. (See 1-3C)

ICC or DOT marking must be on each cylinder. It is an assurance of safety when the cylinder is properly handled.

Identifying gas content. Use only cylin-

ders with name of gas marked on them; do not rely on color to identify gas content. Notify supplier if unmarked. NEVER DEFACE or alter name, number, or other markings on a cylinder. It is illegal and hazardous.

Empties: Keep valves closed, replace caps securely; mark MT; keep them separate from FULLS, and return promptly.

Prohibited use. Never use a cylinder or its contents for other than its intended use, NEVER as a support or roller.

Locate or secure cylinders so they cannot be knocked over.

Passageways and work areas. Keep cylinders clear of areas where they may be stuck.

Transporting cylinders. With a crane, use a secure support such as a platform or cradle. Do NOT lift cylinders off the ground by their valves or caps, or by chains, slings, or magnets.

Do NOT expose cylinders to excessive heat, sparks, slag, and flame, etc. that may cause rupture. Do not allow contents to exceed 55° C (130° F.) Cool with water spray where such exposure exists.

Protect cylinders, particularly valves from bumps, falls, falling objects, and weather. Replace caps securely when moving cylinders.

Stuck valve. Do NOT use a hammer or wrench to open a cylinder valve that cannot be opened by hand. Notify your supplier.

Mixing gases. NEVER try to mix any gases in a cylinder.

NEVER refill any cylinder.

Cylinder fittings should never be modified or exchanged.

3. Hose

Prohibited use. Never use hose other than that designed for the specified gas. A general hose identification rule is: red for fuel gas, green for oxygen, and black for inert gases.

Use ferrules or clamps designed for the hose (not ordinary wire or other substitute) as a binding to connect hoses to fittings.

No copper tubing splices. Use only standard brass fittings to splice hose.

Avoid long runs to prevent kinks and abuse. Suspend hose off ground to keep it from being run over, stepped on, or otherwise damaged.

Coil excess hose to prevent kinks and tangles.

Protect hose from damage by sharp edges, and by sparks, slag, and open flame.

Examine hose regularly for leaks, wear, and loose connections. Immerse pressured hose in water; bubbles indicate leaks

Repair leaky or worn hose by cutting area out and splicing. Do NOT use tape.

4. Proper Connections

Clean cylinder valve outlet of impurities that may clog orifices and damage seats before connecting regulator. Except for hydrogen,

crack valve momentarily, pointing outlet away from people and sources of ignition. Wipe with a clean, lintless cloth.

Match regulator to cylinder. Before connecting, check that the regulator label and cylinder marking agree, and that the regulator inlet and cylinder outlet match. NEVER Connect a regulator designed for a particular gas or gases to a cylinder containing any other gas.

Tighten connections. When assembling threaded connections, clean and smooth seats where necessary. Tighten. If connection leaks, disassemble, clean, and retighten, using properly fitting wrench.

Adapters. Use a CGA adapter (available from your supplier) between cylinder and regulator, if one is required. Use two wrenches to tighten adapter marked RIGHT and LEFT HAND threads.

Regulator outlet (or hose) connections may be identified by right hand threads for oxygen and left hand threads (with grooved hex on nut or shank) for fuel gas.

5. Pressurizing Steps:

Drain regulator of residual gas through suitable vent before opening cylinder (or manifold valve) by turning adjusting screw in (clockwise). Draining prevents excessive compression heat at high pressure seat by allowing seat to open on pressurization. Leave adjusting screw engaged slightly on single-stage regulators.

Stand to side of regulator while opening cylinder valve.

Open cylinder valve slowly so that regulator pressure increases slowly. When gauge is pressurized (gauge reaches regulator maximum) leave cylinder valve in following position: for oxygen and inert gases, open fully to seal stem against possible leak; for fuel gas, open to less than one turn to permit quick emergency shut-off.

Use pressure charts (available from your supplier) for safe and efficient recommended pressure settings on regulators.

Check for leaks on first pressurization and regularly thereafter. Brush with soap solution. Bubbles indicate leaks. Clean off soapy water after test; dried soap is combustible.

E. User Responsibilities

Follow all Safety Rules.

Remove leaky or defective equipment from service immediately for repair. Read and follow user manual instructions.

F. Leaving Equipment Unattended

Close gas supply at source and drain gas.

G. Rope Staging-Support

Rope staging-support should not be used for welding or cutting operation; rope may burn.

1-3 ARC WELDING

Comply with precautions in 1-1, 1-2, and this section. Arc Welding, properly done, is a safe process, but a careless operator invites trouble. The equipment carries high currents at significant voltages. The arc is very bright and hot. Sparks fly, fumes rise, ultraviolet and infrared energy radiates, weldments are hot, and compressed gases may be used. The wise operator avoids unnecessary risks and protects himself and others from accidents.

A. Burn Protection

Comply with precautions in 1-2.

The welding arc is intense and visibly bright. Its radiation can damage eyes, penetrate lightweight clothing, reflect from light-colored surfaces, and burn the skin and eyes. Skin burns resemble acute sunburn; those from gas-shielded arcs are more severe and painful. DON'T GET BURNED; COMPLY WITH PRECAUTIONS.

1. Protective Clothing

Wear long-sleeve clothing in addition to gloves, hat, and shoes. As necessary, use additional protective clothing such as leather jacket or sleeves, flameproof apron, and fire-resistant leggings. Avoid outer garments of untreated cotton.

Bare skin protection. Wear dark, substantial clothing. Button collar to protect chest and neck, and button pockets to prevent entry of sparks.

2. Eye and Head Protection

Protect eyes from exposure to arc. Eyes may be damaged by radiant energy when exposed to the electric arc, even when not looking in the direction of the arc. Never look at an electric arc without protection.

Welding helmet or shield containing a filter plate shade no. 12 or denser must be used when welding. Place over face before striking arc.

Protect filter plate with a clear cover plate.

Cracked or broken helmet or shield should NOT be worn; radiation can be passed through to cause burns.

Cracked, broken, or loose filter plates must be replaced IMMEDIATELY. Replace clear cover plate when broken, pitted, or spattered.

Flash goggles with side shields MUST be worn under the helmet to give some protection to the eyes should the helmet not be lowered over the face before an arc is struck. Looking at an arc momentarily with unprotected eyes (particularly a high intensity gas-shielded arc) can cause a retinal burn that may leave a permanent dark area in the field of vision.

3. Protection of Nearby Personnel

Enclose the welding area. For production welding, a separate room or enclosed bay is best. In open areas, surround the

operation with low-reflective, noncombustible screens or panels. Allow for free air circulation, particularly at floor level.

Viewing the weld. Provide face shields for all persons who will be looking directly at the weld.

Others working in area. See that all persons are wearing flash goggles.

Before starting to weld, make sure that screen flaps or bay doors are closed.

B. Toxic Fume Prevention

Comply with precautions in 1-2B.

Generator engine exhaust must be vented to the outside air. Carbon monoxide can kill.

C. Fire and Explosion Prevention

Comply with precautions in 1-2C.

Equipment's rated capacity. Do not overload arc welding equipment. It may overheat cables and cause a fire.

Loose cable connections may overheat or flash and cause a fire.

Never strike an arc on a cylinder or other pressure vessel. It creates a brittle area that can cause a violent rupture or lead to such a rupture later under rough handling.

D. Compressed Gas Equipment

Comply with precautions in 1-2D.

E. Shock Prevention

Exposed electrically hot conductors or other bare metal in the welding circuit, or in ungrounded, electrically-HOT equipment can fatally shock a person whose body becomes a conductor. DO NOT STAND, SIT, LIE, LEAN ON, OR TOUCH a wet surface when welding without suitable protection.

To protect against shock:

Keep body and clothing dry. Never work in damp area without adequate insulation against electrical shock. Stay on a dry duckboard, or rubber mat when dampness or sweat cannot be avoided. Sweat, sea water, or moisture between body and an electrically HOT part - or grounded metal - reduces the body surface electrical resistance, enabling dangerous and possibly lethal currents to flow through the body.

1. Grounding the Equipment

When installing, connect the frames of each unit such as welding power source, control, work table, and water circulator to the building ground. Conductors must be adequate to carry ground currents safely. Equipment made electrically HOT by stray currents may shock, possibly fatally. Do NOT GROUND to electrical conduit, or to a pipe carrying ANY gas or a flammable liquid such as oil or fuel.

Three-phase connection. Check phase requirement of equipment before installing. If only three-phase power is available, connect single-phase equipment to only two wires of the three-phase line. Do NOT connect the equipment ground lead to the third (live) wire, or the equipment will become electrically HOT - a danger-

ous condition that can shock, possibly fatally.

Before welding, check ground for continuity. Be sure conductors are touching bare metal of equipment frames at connections.

If a line cord with a ground lead is provided with the equipment for connection to a switch box, connect the ground lead to the grounded switch box. If a three-prong plug is added for connection to a grounded mating receptacle, the ground lead must be connected to the ground prong only. If the line cord comes with a three-prong plug, connect to a grounded mating receptacle. Never remove the ground prong from a plug, or use a plug with a broken ground prong.

2. Connectors

Fully insulated lock-type connectors should be used to join welding cable lengths.

3. Cables

Frequently inspect cables for wear, cracks, and damage. IMMEDIATELY REPLACE those with excessively worn or damaged insulation to avoid possibly lethal shock from bared cable. Cables with damaged areas may be taped to give resistance equivalent to original cable.

Keep cable dry, free of oil and grease, and protected from hot metal and sparks.

4. Terminals and Other Exposed Parts

Terminals and other exposed parts of electrical units should have insulating covers secured before operation.

5. Electrode Wire

Electrode wire becomes electrically HOT when the power switch of gas metal-arc welding equipment is ON and welding gun trigger is pressed. Keep hands and body clear of wire and other HOT parts.

6. Safety Devices

Safety devices such as interlocks and circuit breakers should not be disconnected or shunted out.

Before installation, inspection, or service of equipment, shut OFF all power, and remove line fuses (or lock or red-tag switches) to prevent accidental turning ON of power. Disconnect all cables from welding power source, and pull all 115 volts line-cord plugs.

Do not open power circuit or change polarity while welding. If, in an emergency, it must be disconnected, guard against shock burns or flash from switch arcing.

Leaving equipment unattended. Always shut OFF, and disconnect all power to equipment.

Power disconnect switch must be available near the welding power source.

Please Examine Carton and Equipment For Damage Immediately

When this equipment is shipped, title passes to the purchaser upon receipt by the carrier. Consequently, claims for material damaged in shipment must be made by the purchaser against the transportation company at the time the shipment is received.

Please record your equipment identification information below for future reference. This information can be found on your machine nameplate.

Model Name & Number: _____

Code & Serial Number: _____

Date of Purchase: _____

Whenever requesting replacement parts or information on this equipment, always supply the information you have recorded above.

Read this Owner's Manual completely before attempting to use this equipment. Save this manual and keep it handy for quick reference. Pay particular attention to the safety instructions we have provided for your protection.

Table of Contents

Safety Guidelines	i - iii
Installation	Section A
Technical Specifications	3
Electrical	3
Mechanical	3
Weldhead Connections	3
Collet Selection	4
Tungsten Electrode	5
Gas Flow Rates	7
Weldhead Coolant	7
Operations	Section B
Weldhead Calibration	7
Accessories	Section C
Benchmount	9
Extension Cable	9
Collets	9
Maintenance	Section D
Preventative Maintenance	10
Rotor Accuracy	10
Cable Assembly	10
Troubleshooting	Section E
Arc Start Troubleshooting	11
Operational Troubleshooting	11
Figures	Section F
Figure 1 Dimensions	14
Figure 2 Extension Cable Assembly	15
Parts Lists	Section G
Appendix A Collets	19
Appendix B Locating Mandrels	19
Appendix C Pre-Ground Tungsten Electrodes	19
Warranty	

THIS PAGE INTENTIONALLY BLANK

Section A

Installation

Technical Specifications

The MiniMicro™ weldhead was designed for precision welding of small diameter tubes and fittings. The MiniMicro™ weldhead is capable of welding 1/8" to 1/2 inch OD tubes and associated fittings.

Electrical

The MiniMicro™ uses a 24VDC motor with TACH feedback. It is controlled by an orbital power-supply motor-control circuit to turn the rotor at the precise speed to create a near perfect weld.

Mechanical

Power Cable Size: #6, 75A, 600V.
Twist-lock cable-end connectors.

Gas/Water Hose Size: Nylon Tube, 1/4" OD x 0.17 ID
Double-end shut-off coupler

Control Cable Specification: ... 20AWG, 12 conductor

Weldhead Connections

The MiniMicro™ comes equipped with an integrated 12 foot cable, which can connect (with the CobraCooler™ installed) to either the CobraTig® 150 or the Advanced Color Logic™ (ACL) orbital power-supply. The cable assembly provides a path for weld power, operator control and motor signals, inert gas flow, and recirculating coolant flow (see Figure 1).

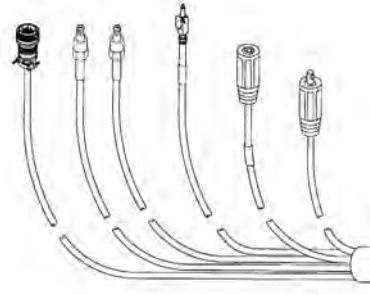

Figure 1

MK Orbital Power Supplies

The MiniMicro™ connects directly to either the CobraTig® 150 or the ACL orbital power-supply with the addition of Pig Tails and the CobraCooler™.

Connecting to the CobraTig® 150

The MiniMicro™ connects directly to the CobraTig® 150 orbital power-supply with a CobraCooler™ installed with its integrated 12 foot cable.

Connecting to the ACL

The MiniMicro™ connects to the ACL orbital power-supply with a Pig Tail Kit (P/N 005-0619) and a CobraCooler™ (Model 250-150).

Section A Cont.

Welding Leads

The two welding Power Leads use a twist-lock type of power connector. These are designed to attach directly to the rear panel of the CobraTig® 150.

The male connector connects to the receptacle labeled "ELECTRODE". The female connector connects to the receptacle labeled "GROUND".

Control Cable

The 24 MS-type pin connector attaches to the mating receptacle on the rear panel of the orbital welding power-supply. All of the Control, Feedback and Welding functions of the weldhead transfer through this connector.

The operator controls are on the weldhead handle. They include: JOG, GAS/NEXT LEVEL, FINAL SLOPE and START/STOP.

Gas Hose

The gas connector is a double-end shut-off type valve that prevents flow or leakage out of either the unit or the gas hose if the connection is broken.

The gas hose connector from the weldhead plugs into the "GAS OUT" receptacle.

Water Hoses

The water connectors are a quick-release type that prevent flow or leakage out of either the CobraCooler™ or the water hose if the connection is broken.

The water hose connectors from the weldhead plug into the "WATER IN" & "WATER OUT" receptacles on the rear panel of the CobraCooler™.

Collets

The three-piece collet assembly mounts to both the jaws and the bottom face plate of the weldhead and maintain the weld joint alignment of the parts to be welded. The collets are manufactured to correspond with the outside diameter of the material to be welded. Each set of collets has three pieces; two sides and one bottom. Two sets of collets are needed to weld two tubes together.

Collet Adjustment (Extended Collets Only)

The parts to be welded are held in place by the Collets. The tolerance of the outside diameter of tubes and pipes vary, so these variations are handled through the use of brass-tipped setscrews, referred to as plungers, in the top Collet halves. These plungers not only make up the diameter difference between the Collet and the part to be welded, but they also act as an aid in the grounding path between the weldhead and the tube or pipe to be welded. The tube or pipe is forced down into the bottom halves of the Collets, which are screwed to a line-bored concentric face in the weldhead side-plates.

The plungers are adjusted as follows:

1. Back the plungers out until the brass tip is flush or below the surface of the bored Collet surface.
2. Place the parts to be welded into the Collets and clamp down the latches.
Adjust the latching mechanism of the weldhead to ensure a tight, but not overly-tight clamping of the Side Plate Jaws.
3. Alternately adjust the plungers on one side of the weldhead until contact is made, and then add about 1/4 turn more.
4. At this point the tube should be firmly held in place. The tube should not turn if attempting to rotate it by hand.

Section A Cont.

5. Repeat the process for the opposite side of the weldhead.
6. Once completed, check the alignment of the parts. A misalignment may be corrected by moving the left or right plunger in or out by a fraction of a turn and then repeating the opposite action to the opposing plunger on the same Collet.

Tungsten Electrode

The recommended tungsten type to be used in the MiniMicro™ and the MK orbital welding system is 2% Ceriated, 1/16 inch diameter.

Appendix C gives the MK part numbers for pre-ground tungsten electrodes required for a specified tube diameter. These lengths of tungsten are long enough to allow the setscrew to securely hold the tungsten while maintaining a relatively close arc gap, and keep the tungsten from sticking out the back of the rotor while using a large arc gap.

Tungsten Geometry

The recommended grind angle and shape for tungsten is 18° included angle and a .015 inch flat (Figure 2). Regardless of the electrode tip geometry selected; it is important that consistent electrode geometry be used once a welding procedure is established.

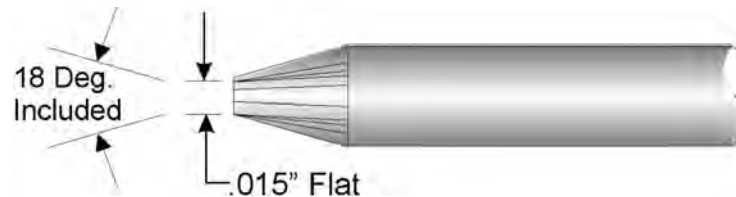

Figure 2

Changes in electrode geometry can significantly influence the weld bead shape and size; therefore, electrode tip configuration is a welding variable that should be defined during procedure development.

Tungsten Preparation

Tungsten electrodes should be properly ground for consistent results. If the electrode is to be hand ground, use a dedicated diamond wheel. The grinding marks should be perpendicular to the tungsten electrode or poor arc starts, arc wander and inclusions may occur (See Figure 3). No other parts should be ground with these wheels, since contamination of the electrode could result and create problems with arc initiation, arc wander during the weld and tungsten inclusions in the weld bead.



Correct - Lengthwise grind marks don't restrict current. Diamond ground mirror finish is best.



Incorrect - Crosswise grind marks restrict welding current, cause arc wander, risk inclusions.

Figure 3

Section A Cont.

All tungsten supplied by MK Products, Inc. is prepared using the latest manufacturing techniques in order to meet the geometry specifications as described above.

Installing the Tungsten Electrode

The electrode is mounted in the rotor and held in place with a setscrew.

To insert the electrode, jog the rotor around until both the tungsten hole and the tungsten set screw are visible in the top of the rotor. Loosen the tungsten setscrew. Insert a properly prepared electrode from the top of the rotor and tighten the setscrew. Be sure to set the appropriate arc gap prior to welding.

Setting the Arc Gap

1. Place the part to be welded on the lower Collets with the clamps in the upright open position.
2. Place the appropriate thickness gauge between the tungsten electrode and the part to be welded so that the tungsten electrode is at the correct gap.

Be certain the thickness gauge is perpendicular to the tungsten electrode.

3. Tighten the setscrew to secure the tungsten electrode in the rotor.

Recommended Arc Gap

The proper arc gap is an important part of the proper use of your orbital welding equipment. Improper arc gap can cause arc strikes to occur to your Collets or to the Side Plate Clamp.

Be sure the arc gap is as short as possible, consistent with the process and weld current level, but not so short as to 'crash' or touch the weld being made.

If no arc gap is known when designing a weld procedure a good rule-of-thumb is as follows:

$$\text{Arc Gap} = (\text{Wall Thickness} \times 0.5) + .010''$$

CAUTION

Do not over-tighten the tungsten set screw. Over-tightening the setscrew can crack and splinter the tungsten causing errant starts and arc wander.

Be sure that the tungsten does not extend into the rotor teeth and that both setscrews are flush with the rotors surface.

Any length of tungsten that is protruding out the back of the rotor will jam with the meshing gears inside the weldhead. This will push the tungsten into the weld being made and inevitably cause an ARC FAULT.

If the weldhead becomes jammed, a "Motor Stall" will result. Usually, some foreign matter, or a piece of tungsten electrode has fallen within the gear mechanism of the weldhead, hindering the rotation of the gears.

Clearing a Jammed Weldhead

In order to clear the jam, turn the weldhead upside-down and vigorously shake the weldhead.

Before turning the weldhead right side up, attempt to locate the foreign object. If the jam cannot be cleared in this manner, the weldhead must be returned to MK for disassembly to have the objects removed.

Section A Cont.

Gas Flow Rates

Recommended arc gas flow rate is 15 to 20 CFH at 50 PSI with the ACL and 20 CFH with the CobraTig® 150. Flow rates higher than 25 CFH can create turbulence within the weldhead chamber and blow the arc about.

Back-up gas flow rates are typically between 5 and 20 CFH, depending on internal volume and component configuration. Typically, when welding components with relatively large internal volumes, a separate source for backup purge gas is recommended.

Weldhead Coolant

Only coolant solutions that are recommended by MK Products, Inc., and/or its distributors, for use in its products, are suitable for use in the MiniMicro™ weldhead. Use a name-brand additive, (which does not contain reactive sulphur or chlorine and does not react with copper, brass or aluminum) or create a custom mix using this formula:

A solution of:

3 Quarts (2.85 Liters) Distilled water

1 Quart (.95 Liters) ethylene glycol

1 tsp (5 ml) liquid glycerin.

Tap water should not be used since it may hinder arc starting.

DO NOT USE AUTOMOTIVE ANTI-FREEZE.

*This may contain additives that are not compatible with this equipment
And will Void the Warranty.*

Section B

Operation

Weldhead Calibration

The software program in the orbital welding power-supply provides for weldhead rotor speed and motor controller calibration. This calibration program consists of driving the rotor at two predetermined speeds (set by the operator) for one revolution at each speed. The start and end of each rotation are detected by the passage of the reed switch or "home" sensor in the weldhead. The rotation is clocked by the computer and, by process of adjusting and recalculating, provides very accurate and consistent speeds.

NOTE

***IT IS RECOMMENDED THAT THE WELDHEAD BE
CALIBRATED EACH TIME THE SYSTEM IS TURNED 'ON'.
FAILURE TO CALIBRATE THE WELDHEAD MAY RESULT IN THE
WELDHEAD OPERATING AT A "ROUGH" ADJUSTMENT THAT
MAY NOT PROVIDE CORRECT ROTOR SPEED AGAINST THE
CONTROLLERS DEMAND SPEED.***

The following paragraphs describe the weldhead calibration results when being used on the MK Orbital ACL 200 Amp welding power-supply and the CobraTig. 150 welding power-supply.

Section B Cont.

ACL

A report is generated showing the 'measured' time for each revolution of the weldhead. The two readings are averaged together to give the 'actual' time in seconds. This value divided into 60 seconds provides the 'actual' rpm. From these results a 'Gain error' and a 'Zero error' is calculated. These are printed as percentages on the report, and are used by the computer to convert the speed demanded by the procedure into a speed, which will result in the proper actual value by the motor control.

The report also shows the data for the tachometer, and computes a corresponding Gain and Zero error value. The computer corrects the motor speed values shown by the display bar graph to represent true values.

The far right column of the report shows an 'Update' value for the motor and tachometer. This update column is only present when using a weld procedure with the "Pre Weld Home" option. Prior to beginning a weld, a procedure with this option will cause the rotor to complete one revolution at the high speed used in the initial calibration. The computer times this revolution and a gain correction is derived. The purpose of this procedure is to calibrate the weldhead before each weld where environmental changes may affect the weldhead speed.

Motor Calibration Data

08/07/01 15:45:04 / 08/07/01 15:45:04"Gain Error = 3.5% / Zero error = 0.05 RPM

<i>Cal</i>	<i>Actual</i>	<i>Cal</i>	<i>Actual</i>	<i>Measured</i>		<i>Update</i>
<i>RPM</i>	<i>RPM</i>	<i>Sec</i>	<i>Sec</i>	<i>Sec</i>	<i>Sec</i>	<i>Sec</i>
6.00	5.84	10.00	10.27	10.27	10.26	0.00
2.00	1.98	30.00	30.36	30.60	30.05	

Tachometer: Gain error = -4.1% / Zero error = 0.13 RPM

<i>Actual</i>	<i>Read</i>	<i>Measured</i>		<i>Update</i>
<i>RPM</i>	<i>RPM</i>	<i>RPM</i>	<i>RPM</i>	<i>Sec</i>
5.84	5.96	5.96	5.96	0.00
1.98	1.93	1.91	1.94	

When a new or repaired weldhead is received, a calibration should be run to "benchmark" its performance. This initial "benchmark" calibration check can then be used to compare prior calibration reports to determine the condition of the weldhead. If the 'Gain error' is more than 10% and 'Zero error' more than .5 rpm off of the benchmark calibration then the weldhead should be disassembled and cleaned.

If the 'Gain error' reaches 50% or the 'Zero error' reaches 2 rpm during a calibration check, the computer will state "DO NOT WELD". At this point, however, the weldhead may have sustained considerable damage. Therefore, it is important to monitor the 'Gain error' and 'Zero error' and provide maintenance as necessary.

**Section
B Cont.**

Motor Calibration Data

08/07/01 15:45:04 / 08/07/01 15:45:04 "Gain Error = 3.5% / Zero error = 0.05 RPM

<i>Cal</i> <i>RPM</i>	<i>Actual</i> <i>RPM</i>	<i>Cal</i> <i>Sec</i>	<i>Actual</i> <i>Sec</i>	<i>Measured</i>		<i>Update</i> <i>Sec</i>
6.00	0.00	10.00	0.00	0.00	0.00	0.00
2.00	1.98	30.00	30.36	30.60	30.05	

Tachometer: Gain error = -4.1% / Zero error = 0.13 RPM

<i>Actual</i> <i>RPM</i>	<i>Read</i> <i>RPM</i>	<i>Measured</i>		<i>Update</i> <i>Sec.</i>
0.00	0.00	0.00	0.00	0.00
1.98	1.93	1.91	1.94	

Cal Time Error: *DO NOT WELD*

CobraTig® 150

The report generated by this unit is not as elaborate as the report from the ACL, however; it does show some very important information. It shows both the MOTOR and TACH gain values. The calibration and adjustment is still the same. The Zero Offset for both the MOTOR and TACH is also shown:

MOTOR Calibration report

MOTOR gain: -4.6% Zero offset: 0.30 RPM
TACH gain: 1.9% Zero offset: 0.02 RPM

Should these MOTOR & TACH gain values return with number of 0.00% and 0.00 RPM, the calibration was invalid and should be re-run.

Results containing all zeros are an indication that the weldhead is in need of service:

MOTOR Calibration report

MOTOR gain: 0.0% Zero offset: 0.00 RPM
TACH gain: 0.0% Zero offset: 0.00 RPM

NOTE: If all values for MOTOR or WELDER calibration are zeros, "it means that he calibration did not complete successfully and is not valid.

Section C

Accessories

Benchmount

The MiniMicro™ weldhead can be used while held in the operator's hand. However, at times it may be necessary for the operator to use both hands to manipulate parts within the weldhead, which requires the use of a Benchmount. This Benchmount (P/N 005-0634) can be affixed to any table or counter edge and can hold the MiniMicro™ Model 4000 orbital weldhead.

Section C Cont.

Extension Cable

When longer weldhead cables are needed, a weldhead extension cable is also available in a 25' length. The extension cable (P/N 005-0635) has all the necessary connections needed to connect the MiniMicro™ to the CobraTig 150: welding leads, gas, coolant supply and return and control interface, or to an ACL using the Pig Tail Kit (P/N 005-0619).

Collets

A set of Collets is defined as 3 each 120° segments for each side of the weldhead. Typically, 2 sets are required per each weldhead (See Appendix A for Part Numbers).

Section D

Maintenance

Due to the complexity of the MiniMicro™; there is no maintenance permitted for the MiniMicro™ with the exception of preventive maintenance, adjustments and replacement of consumables.

Preventative Maintenance

Prior to performing any maintenance, the weldhead should be tested to “benchmark” its performance. A normal calibration should be run and the required correction noted. If the weldhead is running slowly, this usually indicates that there is an excessive load on the drive motor, and that maintenance is required.

Rotor Accuracy

Weld uniformity depends on the accuracy of the position of the rotor during welding. Rotor rotation should be circular in motion in a plane at right angles to the tube and concentric with the center of the tube to be welded. Any deviation from the proper tracking or discontinuity in the rotor will appear in the weld.

Problems in the plane of rotation are usually associated with Collets and can be corrected by Collet modification. Discontinuities with rotor motion are more serious and may require replacement of the rotor, the race, or both. Proper replacement requires factory tooling and is not a field repair.

Cable Assembly

An electrical measurement should be made to determine continuity from the positive cable connector to the rotor and from the negative cable connector to the jaws on the weldhead.

Resistance measurements should be less than 0.1 ohms.

A measurement should also be made to verify that no conductivity exists between the positive and negative power cables. Any measurable conductivity through the weldhead will severely reduce arc start reliability.

The resistance measurement must be greater than 20 MΩ when measured between the tungsten and the jaws.

A visual inspection should be made to determine the condition of the weldhead and the cable assembly. If there are damaged or worn items, the weldhead should be returned for factory service.

Section E

Troubleshooting

Arc Start Troubleshooting

If you experience intermittent arc start problems or strikes to the Collet or Side Plate Clamp instead of the part to be welded, check for the following:

1. The proper arc gap is an important part of the proper use of your MK Orbital equipment. Improper arc gap can cause arc strikes to occur to your Side Plate Clamp or Collets.
2. Be sure that the tungsten is ground properly, (18° included angle and a .015" - .017" flat at the end of the tip). Sharpening should be accomplished with the grind marks parallel to the longitudinal axis of the tungsten, not around the tungsten (reference Figure 3).
3. Parts must be clean with no oxidation, oils or other insulating surface contaminant.
4. If the tungsten is contaminated at any time, it should be replaced. Dirty tungsten can cause poor arc starts and tungsten inclusions.
5. Make sure that the part to be welded is tight in the Collets, or a loose ground will result. If the part to be welded can be turned in a latched Collet, tighten the Collet plungers.
6. Avoid any tooling that might have sharp edges or points or this will cause an arc strike to the Collets or the Side Plate Clamp.
7. To insure reliable arc starting and extended tungsten life, the pre-purge settings should be determined by the size of the tube and weldhead size: the smaller the tube in a given size weldhead; the longer the pre-purge time.
8. If an arc strike occurs to the Collet or Side Plate Clamp, the resulting arc spot may induce future arc strikes. Be sure to smooth out any arc spots with a fine abrasive pad or cover it with appropriate insulating tape.
9. Be sure that there is a tube in the weldhead before trying to make a weld.

Operational Troubleshooting

If the weldhead does not return to the 'Home' position, but continues to rotate when the 'Home' switch is pressed; the Reed Switch is most likely defective.

The MiniMicro® weldhead must be returned to the factory for any and all repairs.

THIS PAGE INTENTIONALLY BLANK

Section F

Figures

Figure 1	
Dimensions.....	14
Figure 2	
Extension Cable Assembly.....	15

Figure 1 Dimensions

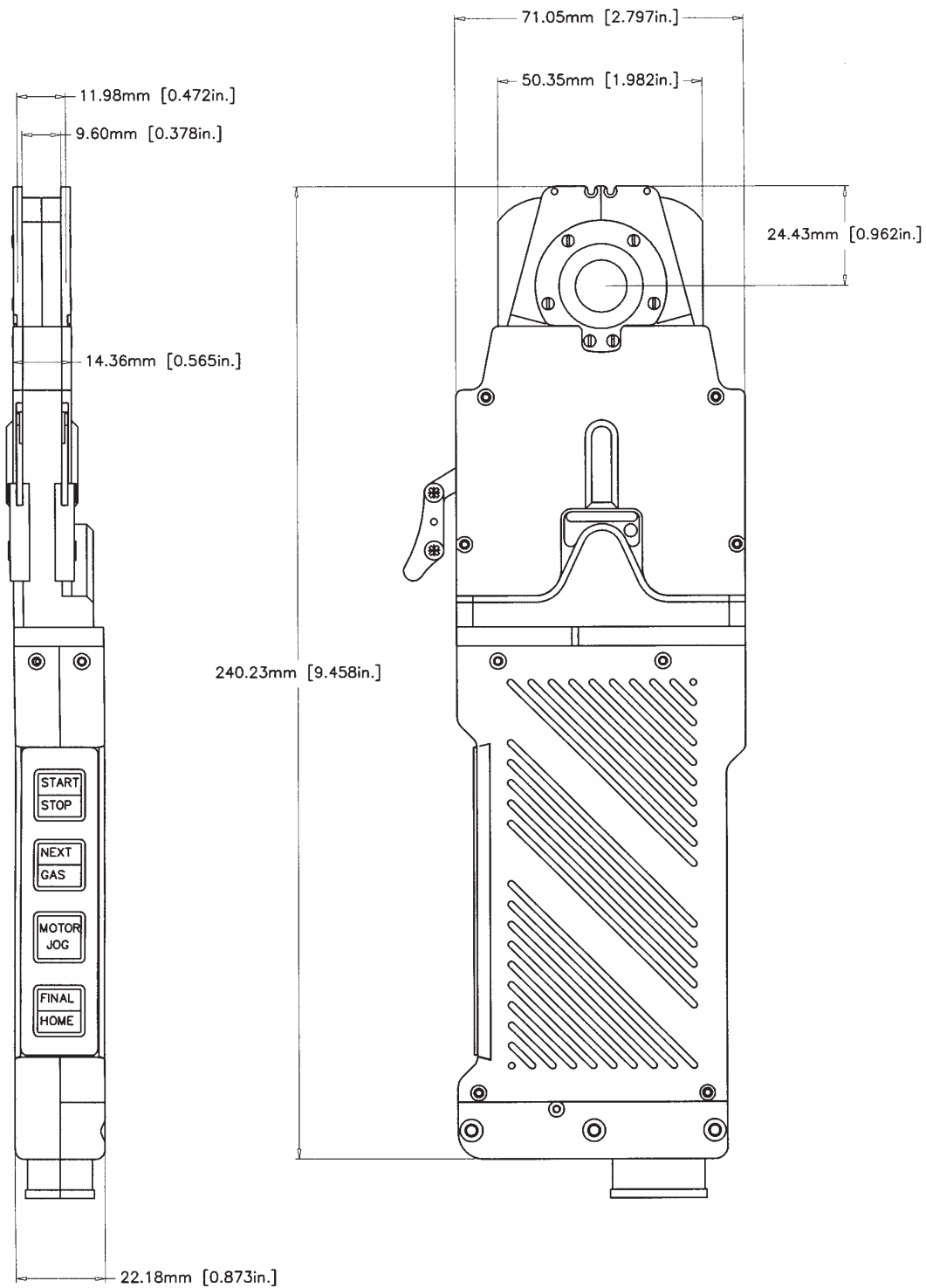
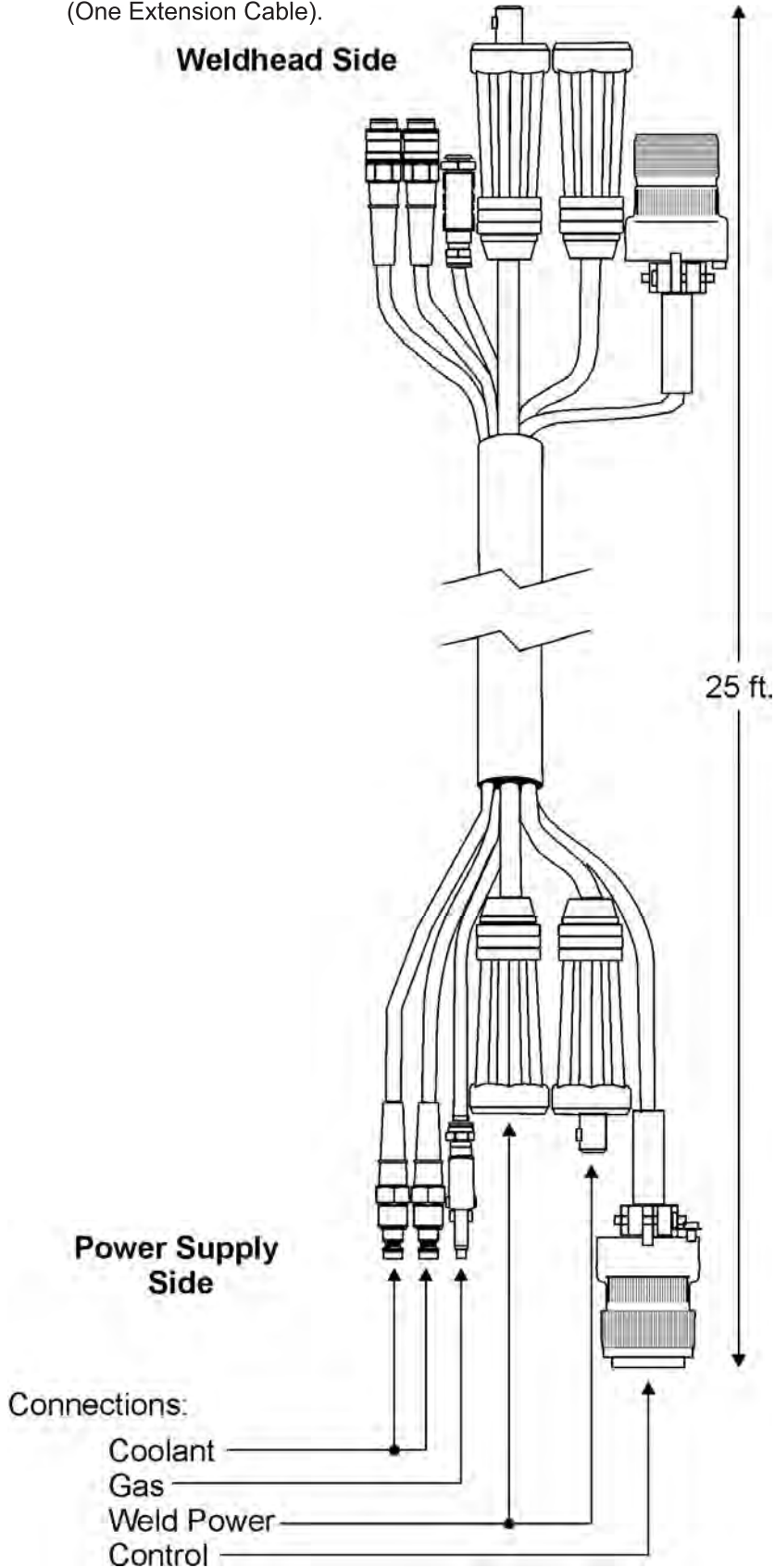

Figure 2
005-0635
Extension Cable Assembly

The Maximum length between the weldhead and the power supply is 37.5 feet
(One Extension Cable).



THIS PAGE INTENTIONALLY BLANK

Section G

Parts Lists

Appendix A Collets.....	19
Appendix B Locating Mandrels.....	19
Appendix C Pre-Ground Tungsten Electrodes	19

THIS PAGE INTENTIONALLY BLANK

Appendix A Collets and Jaws

Description	Part Number	Description	Part Number
Flush Micro-Fit Collets:		Extended Collets:	
1/8".....	623-4010	1/8".....	624-4010
1/4".....	623-4011	1/4".....	624-4011
5/16".....	623-4014	5/16".....	624-4014
3/8".....	623-4012	3/8".....	624-4012
7/16".....	623-4015	7/16".....	624-4015
1/2".....	623-4013	1/2".....	624-4013

Appendix B Locating Mandrels

Description

Part Number



025-0036	LOCATING MANDREL 1/8
025-0025	LOCATING MANDREL 1/4
025-0027	LOCATING MANDREL 3/8
025-0028	LOCATING MANDREL 1/2

Appendix C Pre-Ground Tungsten Electrodes

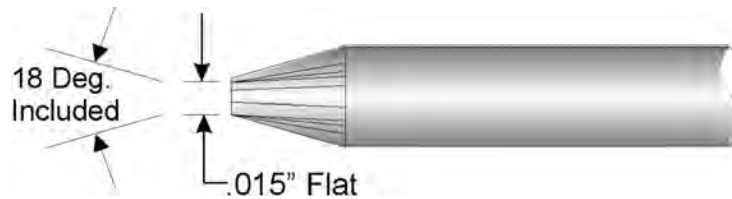

Tungsten Sold in Packages of 10:

1/8"	635-0086
1/4"	635-0087
5/16"	635-0088
3/8"	635-0089
7/16".....	635-0090
1/2"	635-0091

			
WARNING	<ul style="list-style-type: none"> ● Do not touch electrically live parts or electrode with skin or wet clothing. ● Insulate yourself from work and ground. 	<ul style="list-style-type: none"> ● Keep flammable materials away. 	<ul style="list-style-type: none"> ● Wear eye, ear and body protection.
Spanish AVISO DE PRECAUCION	<ul style="list-style-type: none"> ● No toque las partes o los electrodos bajo carga con la piel o ropa mojada. ● Aisiese del trabajo y de la tierra. 	<ul style="list-style-type: none"> ● Mantenga el material combustible fuera del área de trabajo. 	<ul style="list-style-type: none"> ● Protéjase los ojos, los oídos y el cuerpo.
French ATTENTION	<ul style="list-style-type: none"> ● Ne laissez ni la peau ni des vêtements mouillés entrer en contact avec des pièces sous tension. ● Isolez-vous du travail et de la terre. 	<ul style="list-style-type: none"> ● Gardez à l'écart de tout matériel inflammable. 	<ul style="list-style-type: none"> ● Protégez vos yeux, vos oreilles et votre corps.
German WARNUNG	<ul style="list-style-type: none"> ● Berühren Sie keine stromführenden Teile oder Elektroden mit Ihrem Körper oder feuchter Kleidung! ● Isolieren Sie sich von den Elektroden und dem Erdboden! 	<ul style="list-style-type: none"> ● Entfernen Sie brennbares Material! 	<ul style="list-style-type: none"> ● Tragen Sie Augen-, Ohren- und Körperschutz!
Portuguese ATENÇÃO	<ul style="list-style-type: none"> ● Não toque partes elétricas e electrodos com a pele ou roupa molhada. ● Isole-se da peça e terra. 	<ul style="list-style-type: none"> ● Mantenha inflamáveis bem guardados. 	<ul style="list-style-type: none"> ● Use proteção para a vista, ouvido e corpo.
Japanese 注意事項	<ul style="list-style-type: none"> ● 通電中の電気部品、又は溶材にヒフやぬれた布で触れないこと。 ● 施工物やアースから身体が絶縁されている様にして下さい。 	<ul style="list-style-type: none"> ● 燃えやすいものの側での溶接作業は絶対にしてはなりません。 	<ul style="list-style-type: none"> ● 目、耳及び身体に保護具をして下さい。
Chinese 警告	<ul style="list-style-type: none"> ● 皮肤或湿衣物切勿接触带电部件及焊缝。 ● 使你自已与地面和工件绝缘。 	<ul style="list-style-type: none"> ● 把一切易燃物品移离工作场所。 	<ul style="list-style-type: none"> ● 佩戴眼、耳及身体劳动保护用具。
Korean 위험	<ul style="list-style-type: none"> ● 전도체나 용접봉을 젖은 헝겊 또는 피부로 절대 접촉치 마십시오. ● 모재와 접지를 접촉치 마십시오. 	<ul style="list-style-type: none"> ● 인화성 물질을 접근 시키지 마십시오. 	<ul style="list-style-type: none"> ● 눈, 귀와 몸에 보호장구를 착용하십시오.
Arabic تحذير	<ul style="list-style-type: none"> ● لا تلمس الأجزاء التي يمر بها التيار الكهربائي أو الأقطاب بجلد الجسم أو بالملابس المبللة بالماء. ● ضع عازلا على جسمك خلال العمل. 	<ul style="list-style-type: none"> ● ضع المواد القابلة للاشتعال في مكان بعيد. 	<ul style="list-style-type: none"> ● ضع أدوات وملابس واقية على عينيك وأذنيك وجسمك.

READ AND UNDERSTAND THE MANUFACTURER'S INSTRUCTION FOR THIS EQUIPMENT AND THE CONSUMABLES TO BE USED AND FOLLOW YOUR EMPLOYER'S SAFETY PRACTICES.

SE RECOMIENDA LEER Y ENTENDER LAS INSTRUCCIONES DEL FABRICANTE PARA EL USO DE ESTE EQUIPO Y LOS CONSUMIBLES QUE VA A UTILIZAR, SIGA LAS MEDIDAS DE SEGURIDAD DE SU SUPERVISOR.

LISEZ ET COMPRENEZ LES INSTRUCTIONS DU FABRICANT EN CE QUI REGARDE CET EQUIPMENT ET LES PRODUITS A ETRE EMPLOYES ET SUIVEZ LES PROCEDURES DE SECURITE DE VOTRE EMPLOYEUR.

LESEN SIE UND BEFOLGEN SIE DIE BETRIEBSANLEITUNG DER ANLAGE UND DEN ELEKTRODENEINSATZ DES HERSTELLERS. DIE UNFALLVERHÜTUNGSVORSCHRIFTEN DES ARBEITGEBERS SIND EBENFALLS ZU BEACHTEN.

			
<ul style="list-style-type: none"> ● Keep your head out of fumes. ● Use ventilation or exhaust to remove fumes from breathing zone. 	<ul style="list-style-type: none"> ● Turn power off before servicing. 	<ul style="list-style-type: none"> ● Do not operate with panel open or guards off. 	WARNING
<ul style="list-style-type: none"> ● Los humos fuera de la zona de respiración. ● Mantenga la cabeza fuera de los humos. Utilice ventilación o aspiración para gases. 	<ul style="list-style-type: none"> ● Desconectar el cable de alimentación de poder de la máquina antes de iniciar cualquier servicio. 	<ul style="list-style-type: none"> ● No operar con panel abierto o guardas quitadas. 	Spanish AVISO DE PRECAUCION
<ul style="list-style-type: none"> ● Gardez la tête à l'écart des fumées. ● Utilisez un ventilateur ou un aspirateur pour ôter les fumées des zones de travail. 	<ul style="list-style-type: none"> ● Débranchez le courant avant l'entretien. 	<ul style="list-style-type: none"> ● N'opérez pas avec les panneaux ouverts ou avec les dispositifs de protection enlevés. 	French ATTENTION
<ul style="list-style-type: none"> ● Vermeiden Sie das Einatmen von Schweißrauch! ● Sorgen Sie für gute Be- und Entlüftung des Arbeitsplatzes! 	<ul style="list-style-type: none"> ● Strom vor Wartungsarbeiten abschalten! (Netzstrom völlig öffnen; Maschine anhalten!) 	<ul style="list-style-type: none"> ● Anlage nie ohne Schutzgehäuse oder Innenschutzverkleidung in Betrieb setzen! 	German WARNUNG
<ul style="list-style-type: none"> ● Mantenha seu rosto da fumaça. ● Use ventilação e exaustão para remover fumo da zona respiratória. 	<ul style="list-style-type: none"> ● Não opere com as tampas removidas. ● Desligue a corrente antes de fazer serviço. ● Não toque as partes elétricas nuas. 	<ul style="list-style-type: none"> ● Mantenha-se afastado das partes moventes. ● Não opere com os painéis abertos ou guardas removidas. 	Portuguese ATENÇÃO
<ul style="list-style-type: none"> ● ヒュームから頭を離すようにして下さい。 ● 換気や排煙に十分留意して下さい。 	<ul style="list-style-type: none"> ● メンテナンス・サービスに取りかかる際には、まず電源スイッチを必ず切って下さい。 	<ul style="list-style-type: none"> ● パネルやカバーを取り外したまま機械操作をしないで下さい。 	Japanese 注意事項
<ul style="list-style-type: none"> ● 頭部遠離煙霧。 ● 在呼吸區使用通風或排風器除煙。 	<ul style="list-style-type: none"> ● 維修前切斷電源。 	<ul style="list-style-type: none"> ● 儀表板打開或沒有安全罩時不準作業。 	Chinese 警告
<ul style="list-style-type: none"> ● 얼굴로부터 용접가스를 멀리하십시오. ● 호흡지역으로부터 용접가스를 제거하기 위해 가스채거나 통풍기를 사용하십시오. 	<ul style="list-style-type: none"> ● 보수전에 전원을 차단하십시오. 	<ul style="list-style-type: none"> ● 관널이 열린 상태로 작동치 마십시오. 	Korean 위험
<ul style="list-style-type: none"> ● ابتعد رأسك بعيداً عن الدخان. ● استعمل التهوية أو جهاز ضغط الدخان للخارج لكي تبعد الدخان عن المنطقة التي تتنفس فيها. 	<ul style="list-style-type: none"> ● القطع التيار الكهربائي قبل القيام بأية صيانة. 	<ul style="list-style-type: none"> ● لا تشغل هذا الجهاز إذا كانت الاغطية الحديدية الواقية ليست عليه. 	Arabic تحذير

LEIA E COMPREENDA AS INSTRUÇÕES DO FABRICANTE PARA ESTE EQUIPAMENTO E AS PARTES DE USO, E SIGA AS PRÁTICAS DE SEGURANÇA DO EMPREGADOR.

使う機械や溶材のメーカーの指示書をよく読み、まず理解して下さい。そして貴社の安全規定に従って下さい。

請詳細閱讀並理解製造廠提供的說明以及應該使用的銀焊材料，並請遵守貴方的有關勞動保護規定。

이 제품에 동봉된 작업지침서를 숙지하시고 귀사의 작업자 안전수칙을 준수하시기 바랍니다.

اقرأ بتمعن وافهم تعليمات المصنع المنتج لهذه المعدات والمواد قبل استعمالها واتبع تعليمات الوقاية لصاحب العمل.

THIS PAGE INTENTIONALLY BLANK

LIMITED WARRANTY

Effective March 1, 2001

This warranty supersedes all previous MK Products warranties and is exclusive, with no other guarantees or warranties expressed or implied.

LIMITED WARRANTY - MK Products, Inc., Irvine, California warrants that all new and unused equipment furnished by MK Products is free from defect in workmanship and material as of the time and place of delivery by MK Products. No warranty is made by MK Products with respect to trade accessories or other items manufactured by others. Such trade accessories and other items are sold subject to the warranties of their respective manufacturers, if any.

MK Products' warranty does not apply to components having normal useful life of less than one (1) year, such as relay points, wire conduit, tungsten, and welding torch parts that come in contact with the welding wire, including gas cups, gas cup insulators, and contact tips where failure does not result from defect in workmanship or material.

In the case of MK Products' breach of warranty or any other duty with respect to the quality of any goods, the exclusive remedies therefore shall be at MK Products' option:

- (1) repair
- (2) replacement
- (3) where authorized in writing by MK Products, the reasonable cost of repair or replacement at our Irvine, California plant; or
- (4) payment of or credit for the purchase price (less reasonable depreciation based upon actual use) upon return of the goods at customer's risk and expense. Upon receipt of notice of apparent defect or failure, MK Products shall instruct the claimant on the warranty claim procedures to be followed.

As a matter of general policy only, MK Products may honor an original user's warranty claims on warranted equipment in the event of failure resulting from a defect within the following periods from the date of delivery of equipment to the original user:

1. **Torches, Weldheads and Water Recirculators..... 1 year**
2. **All Other Equipment..... 3 years**
3. **Repairs 90 days**

Classification of any item into the foregoing categories shall be at the sole discretion of MK Products. Notification of any failure must be made in writing within 30 days of such failure.

A copy of the invoice showing the date of sale must accompany products returned for warranty repair or replacement.

All equipment returned to MK Products for service must be properly packaged to guard against damage from shipping. MK Products will not be responsible for any damages resulting from shipping.

Normal surface transportation charges (both ways) for products returned for warranty repair or replacement will be borne by MK Products, except for products sold to foreign markets.

ANY EXPRESS WARRANTY NOT PROVIDED HEREIN AND ANY IMPLIED WARRANTY, GUARANTY, OR REPRESENTATION AS TO PERFORMANCE, AND ANY REMEDY FOR BREACH OF CONTRACT WHICH, BUT FOR THIS PROVISION, MIGHT ARISE BY IMPLICATION, OPERATION OF LAW, CUSTOM OF TRADE, OR COURSE OF DEALING, INCLUDING ANY IMPLIED WARRANTY OF MERCHANTABILITY OR OF FITNESS FOR PARTICULAR PURPOSE, WITH RESPECT TO ANY AND ALL EQUIPMENT FURNISHED BY MK PRODUCTS, IS EXCLUDED AND DISCLAIMED BY MK PRODUCTS.

EXCEPT AS EXPRESSLY PROVIDED BY MK PRODUCTS IN WRITING, MK PRODUCTS ARE INTENDED FOR ULTIMATE PURCHASE BY COMMERCIAL/INDUSTRIAL USERS AND FOR OPERATION BY PERSONS TRAINED AND EXPERIENCED IN THE USE AND MAINTENANCE OF WELDING EQUIPMENT AND NOT FOR CONSUMERS OR CONSUMER USE. MK PRODUCTS WARRANTIES DO NOT EXTEND TO, AND NO RE-SELLER IS AUTHORIZED TO EXTEND MK PRODUCTS' WARRANTIES TO ANY CONSUMER.



16882 Armstrong Ave.
Irvine, CA 92606
Tel (949)863-1234
Fax (949)474-1428
www.mkproducts.com

DATE : March 1, 2001



WWW.MKPRODUCTS.COM
16882 ARMSTRONG AVE.
IRVINE, CALIFORNIA 92606
TEL (949) 863-1234 FAX (949) 474-1428